

(D) AUTOS MIT VOM HERSTELLER VORGEGEHEHENEN BEFESTIGUNGSPUNKTEN
(GB) CARS WITH PRE-EXISTING FIXING POINT FROM MANUFACTURER
(F) VOITURES AVEC POINTS DE RÉPÈRE PRÉVUS PAR LE CONSTRUCTEUR
(E) MODELOS CON PREDISPOSICIÓN DEL FABRICANTE
(IT) MODELLI CON PREDISPOSIZIONE DELLA CASA AUTO
(NL) AUTO'S MET DOOR DE FABRIKANT VOORZIENE MONTAGEPUNTEN

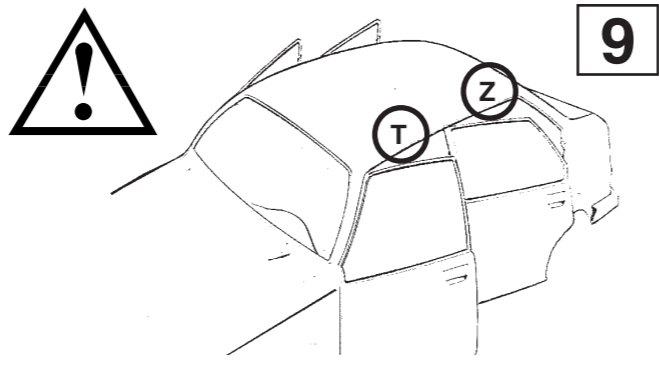

9

(D) Vom Fahrzeughersteller am Dach bzw. in den Türen vorgesehene Befestigungspunkte.
 Siehe Pkw-Handbuch/Betriebsanleitung des Fahrzeugherstellers!
(GB) Original manufacturers fixing points in the roof or in the door shut.
 Check in vehicle handbook.
(F) Les points de fixation du constructeur à l'origine se trouvent sur le toit ou le battant de la porte. Vérifier dans le manuel technique de la voiture.
(E) Los anclajes originales se encuentran en el techo ó en el batiente de la puerta.
 Verificar en el manual del vehículo.
(IT) I punti di fissaggio originali sono sul tetto oppure sul battente della portiera.
 Verificate sul manuale d'uso della vettura.

(D) FESTSCHRAUBEN
(GB) TO SCREW
(F) VISSER
(E) APRETAR
(IT) AVVITARE
(NL) VASTSCHROEVEN

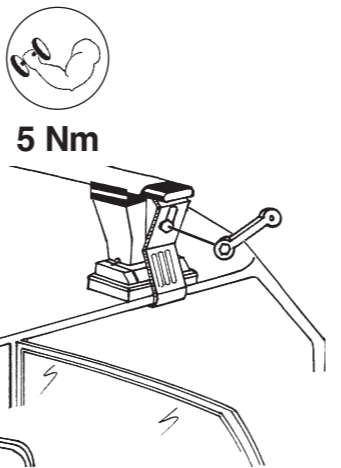

(IT) MODELLI AUTO (GB) CARS (E) COCHES (D) WAGEN (F) VOITURES (NL) AUTO (P) MODELO AUTO (H) AUTÓ TIPUS (PL) MODELE SAMOCHODÓW (SLO) MODELI AVTOMOBILOV (HR) MODELI AUTA	(IT) ANTERIORE (GB) FRONT (E) DELANTERO (D) VORDERE (F) AVANT (NL) VOORSTE G. (P) À FRENTE (H) ELSŐ RÚD (PL) PRZOD (SLO) SPREDAJ (HR) PREDNJI	(IT) POSTERIORE (GB) REAR (E) TRASERO (D) HINTERE (F) ARRIERE (NL) ACHTERSTE G. (P) ATRÁS (H) HÁTSÓ RÚD (PL) TYL (SLO) ZADAJ (HR) STRAŽNJI
HONDA Jazz II MPV (08->15) with or w/o sun roof/ Mit und ohne Glasdach	T	Z
HYUNDAI Accent III 5D (06->10)	T	Z
LEXUS IS 200 4D (99->05)	T	Z
MERCEDES 190 4D W201 (82->93)	T	Z
MERCEDES 200 4D W124 (85->95)	T	Z
MERCEDES C Class 4D W202 (93->00)	T	Z
MERCEDES E Class 4D W210 (95->01)	T	Z
RENAULT Laguna I 4D (94->00)	T	Z
SKODA Superb I 4D (02->07)	T	Z
TOYOTA Avensis 4D (98->02)	T	Z
TOYOTA Avensis 5D (98->02)	T	Z
TOYOTA Avensis 4D (03->08)	T	Z
TOYOTA Avensis 5D (03->08)	T	Z
TOYOTA Carina E 4D (92->98)	T	Z
TOYOTA Carina E 5D (92->98)	T	Z
TOYOTA Corolla Verso MPV (01->04) No rails	T	Z

TWINNY S 02
LOAD





Entsprechen die nachstehenden Sicherheits- und Qualitätsnormen:
 Statische Tests XP ISO/PAS 11154-A (September 2007) und DIN 75302 mit GS-KENNZEICHEN.

(D) MONTAGEANWEISUNGEN **(GB)** FITTING INSTRUCTIONS **(F)** INSTRUCTIONS DE MONTAGE
(E) INSTRUCCIONES PARA SU MONTAJE **(IT)** ISTRUZIONI DI MONTAGGIO **(NL)** MONTAGE INSTRUCTIES.

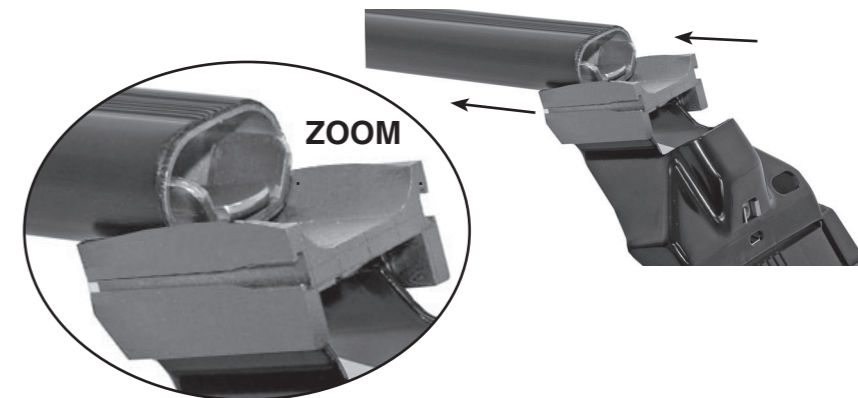
1

(D) STOPFEN
(GB) INSERT
(F) ENFILER
(E) CUBRIR
(IT) INSERIRE
(NL) BEVESTIG



 (IT) MODELLI AUTO (GB) CARS (E) COCHES (D) WAGEN (F) VOITURES	(NL) AUTO (P) MODELO AUTO (H) AUTÓ TIPUS (PL) MODELE SAMOCHODÓW (SLO) MODELI AVTOMOBILOV (HR) MODELI AUTA	 (IT) ANTERIORE (GB) FRONT (E) DELANTERO (D) VORDERE (F) AVANT	 (NL) VOORSTE G. (P) À FRENTE (H) ELSŐ RÚD (PL) PRZOD (SLO) SPREDAJ (HR) PREDNJI	 (IT) POST. (GB) REAR (E) TRASERO (D) HINTERE (F) ARRIERE	 (NL) ACHTERSTE G. (P) ATRÁS (H) HÁTSÓ RÚD (PL) TYL (SLO) ZADAJ (HR) STRAŽNJI
ALFA ROMEO 75 4D (85->92)		112 mm			127 mm
BMW 5er 4D E34 (88->95)		120 mm			120 mm
BMW 5er 4D E39 (96->03)		132 mm			132 mm
DAEWOO Nubira II 4D (03->09)		137 mm			153 mm
DAIHATSU Cuore VI 5D (03->06)		157 mm			151 mm
DAIHATSU Trevis 5D (06->10)		173 mm			170 mm
HONDA Jazz II MPV (08->15) with or w/o sun roof/ Mit und ohne Glasdach		118 mm			141 mm
HYUNDAI Accent III 5D (06->10)		122 mm			138 mm
KIA Picanto I 5D (04->10)		155 mm			142 mm
LEXUS IS 200 4D (99->05)		127 mm			127 mm
MERCEDES 190 4D W201 (82->93)		127 mm			137 mm
MERCEDES 200 4D W124 (85->95)		105 mm			105 mm
MERCEDES C Class 4D W202 (93->00)		127 mm			127 mm
MERCEDES C Class 4D W203 (00->07)		117 mm			128 mm
MERCEDES E Class 4D W210 (95->01)		102 mm			102 mm
MERCEDES E Class 4D W211 (02->08)		106 mm			120 mm
OPEL Agila A MPV (00->07) No rails		115 mm			125 mm
RENAULT Laguna I 4D (94->00)		140 mm			155 mm
SKODA Superb I 4D (02->07)		125 mm			125 mm
SUZUKI Wagon R + 5D (97->00) No rails		115 mm			125 mm
SUZUKI Wagon R + 5D (00->07) No rails		115 mm			125 mm
TOYOTA Avensis 4D (98->02)		157 mm			157 mm
TOYOTA Avensis 5D (98->02)		157 mm			157 mm
TOYOTA Avensis 4D (03->08)		106 mm			112 mm
TOYOTA Avensis 5D (03->08)		106 mm			112 mm
TOYOTA Carina E 4D (92->98)		142 mm			158 mm
TOYOTA Carina E 5D (92->98)		142 mm			158 mm
TOYOTA Corolla Verso MPV (01->04) No rails		111 mm			117 mm

2

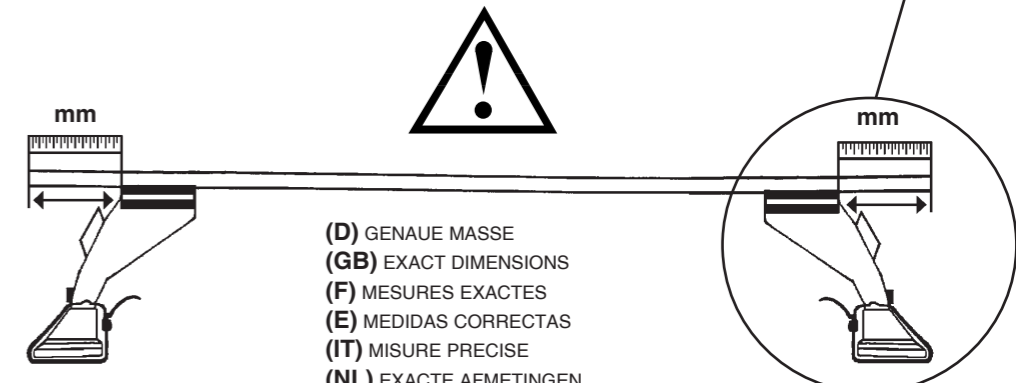
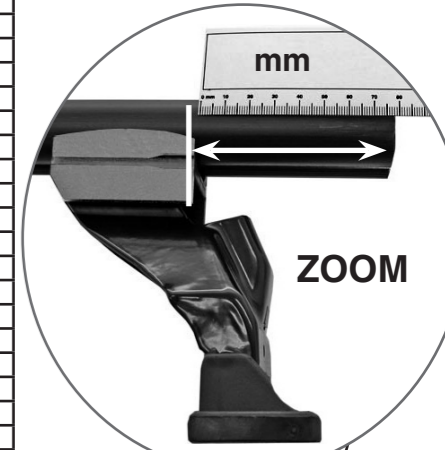

(D) GENAUE MASSE
(GB) EXACT DIMENSIONS
(F) MESURES EXACTES
(E) MEDIDAS CORRECTAS
(IT) MISURE PRECISE
(NL) EXACTE AFMETINGEN

3

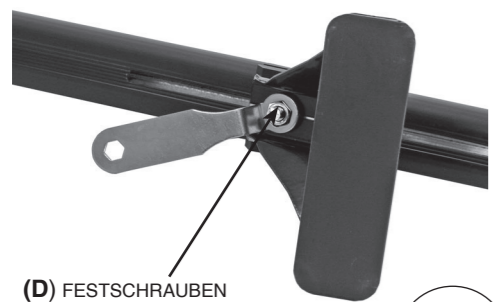

(D) FESTSCHRAUBEN
(GB) TO SCREW (DOWN)
(F) VISSER (À FOND)
(E) APRETAR (A FONDO)
(IT) AVVITARE (A FONDO)
(NL) VASTSCHROEVEN



10 Nm

4



(D) STOPFEN
(GB) INSERT
(F) ENFILER
(E) CUBRIR
(IT) INSERIRE
(NL) BEVESTIG

6

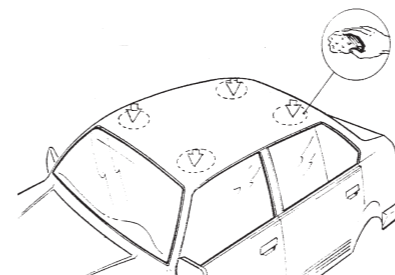

(D) DACH REINIGEN
(GB) CLEAN THE ROOF
(F) NETTOYER LE TOIT
(E) LIMPIAR EL TECHO
(IT) PULIRE IL TETTO
(NL) DAK SCHOONMAKEN

7

(D) LASTENTRÄGER AUF DEM DACH ZENTRIEREN
(GB) CENTRE THE UNIVERSAL BAR CARRIER ON THE ROOF
(F) CENTRER LE PORTE-TOUT SUR LE TOIT
(E) CENTRAR EL PORTAEQUIPAJES SOBRE EL TECHO
(IT) CENTRARE IL P. TUTTO SUL TETTO
(NL) PLAATS DE UNIVERSELE DRAGER IN HET MIDDEN VAN HET DAK

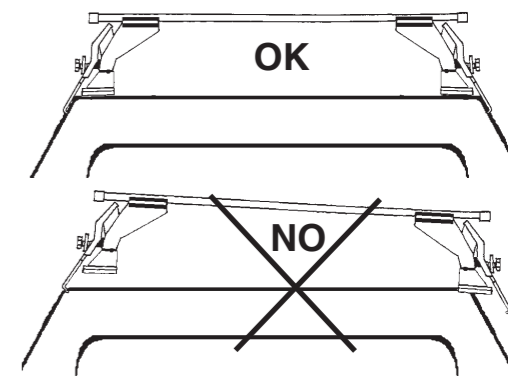

5

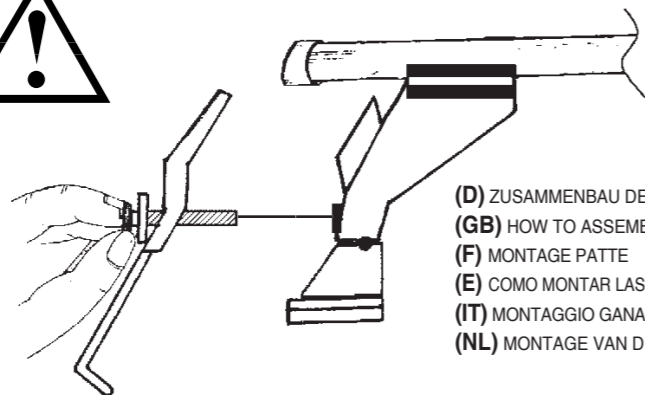
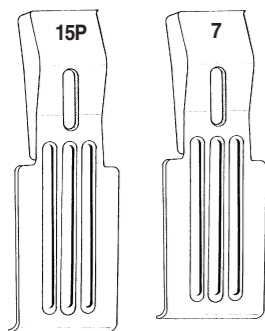

(D) ZUSAMMENBAU DER SPANNBACKEN
(GB) HOW TO ASSEMBLE THE CLAMPS
(F) MONTAGE PATTE
(E) COMO MONTAR LAS FIJACIONES
(IT) MONTAGGIO GANASCINE
(NL) MONTAGE VAN DE KLEMMEN

(IT) MODELLI AUTO (GB) CARS (E) COCHES (D) WAGEN (F) VOITURES (NL) AUTO (P) MODELO AUTO (H) AUTÓ TIPUS (PL) MODELE SAMOCHODÓW (SLO) MODELI AVTOMOBILOV (HR) MODELI AUTA	(IT) ANTERIORE (GB) FRONT (E) DELANTERO (D) VORDERE (F) AVANT (NL) VOORSTE G. (P) À FRENTE (H) ELSŐ RÚD (PL) PRZOD (SLO) SPREDAJ (HR) PREDNJI	(IT) POSTERIORE (GB) REAR (E) TRASERO (D) HINTERE (F) ARRIERE (NL) ACHTERSTE G. (P) ATRÁS (H) HÁTSÓ RÚD (PL) TYL (SLO) ZADAJ (HR) STRAŽNJI
ALFA ROMEO 75 4D (85->92)	7	7
BMW 5er 4D E34 (88->95)	7	7
BMW 5er 4D E39 (96->03)	7	7
DAEWOO Nubira II 4D (03->09)	15P	15P
DAIHATSU Cuore VI 5D (03->06)	7	7
DAIHATSU Trevis 5D (06->10)	15P	15P
HONDA Jazz II MPV (08->15) with or w/o sun roof/ Mit und ohne Glasdach	7	7
HYUNDAI Accent III 5D (06->10)	7	7
KIA Picanto I 5D (04->10)	7	7
LEXUS IS 200 4D (99->05)	7	7
MERCEDES 190 4D W201 (82->93)	7	7
MERCEDES 200 4D W124 (85->95)	7	7
MERCEDES C Class 4D W202 (93->00)	7	7
MERCEDES C Class 4D W203 (00->07)	7	7
MERCEDES E Class 4D W210 (95->01)	7	7
MERCEDES E Class 4D W211 (02->08)	7	7
OPEL Agila A MPV (00->07) No rails	15P	15P
RENAULT Laguna I 4D (94->00)	7	7
SKODA Superb I 4D (02->07)	7	7
SUZUKI Wagon R + 5D (97->00) No rails	15P	15P
SUZUKI Wagon R + 5D (00->07) No rails	15P	15P
TOYOTA Avenis 4D (98->02)	7	7
TOYOTA Avenis 5D (98->02)	7	7
TOYOTA Avenis 4D (03->08)	7	7
TOYOTA Avenis 5D (03->08)	7	7
TOYOTA Carina E 4D (92->98)	7	7
TOYOTA Carina E 5D (92->98)	7	7
TOYOTA Corolla Verso MPV (01->04) No rails	7	7

(D) AUTOS OHNE VOM HERSTELLER VORGESEHENEN BEFESTIGUNGSPUNKTEN
(GB) CARS WITHOUT PRE-EXISTING FIXING POINT
(F) VOITURES SANS POINTS DE RÉPÈRE PRÉVUS PAR LE CONSTRUCTEUR
(E) PARA COCHES SIN PREDISPOSICION DEL FABRICANTE
(IT) MODELLI SENZA PREDISPOSIZIONE DELLA CASA AUTO
(NL) AUTO'S ZONDER DOOR DE FABRIKANT VOORZIENE BEVESTIGINGSPUNTEN

8

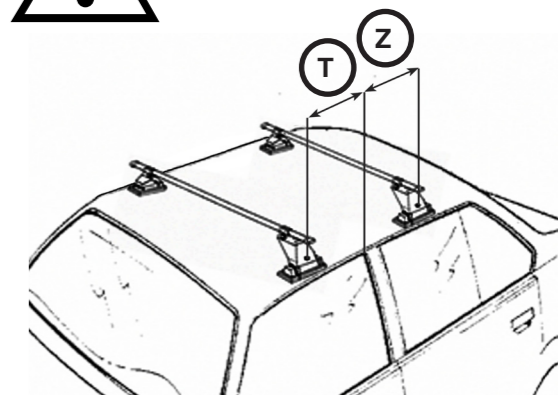

(IT) MODELLI AUTO (GB) CARS (E) COCHES (D) WAGEN (F) VOITURES (NL) AUTO (P) MODELO AUTO (H) AUTÓ TIPUS (PL) MODELE SAMOCHODÓW (SLO) MODELI AVTOMOBILOV (HR) MODELI AUTA	(IT) ANTERIORE (GB) FRONT (E) DELANTERO (D) VORDERE (F) AVANT (NL) VOORSTE G. (P) À FRENTE (H) ELSŐ RÚD (PL) PRZOD (SLO) SPREDAJ (HR) PREDNJI	(IT) POSTERIORE (GB) REAR (E) TRASERO (D) HINTERE (F) ARRIERE (NL) ACHTERSTE G. (P) ATRÁS (H) HÁTSÓ RÚD (PL) TYL (SLO) ZADAJ (HR) STRAŽNJI
ALFA ROMEO 75 4D (85->92)	T=250 mm	Z=450 mm
BMW 5er 4D E34 (88->95)	T=350 mm	Z=350 mm
BMW 5er 4D E39 (96->03)	T=250 mm	Z=450 mm
DAEWOO Nubira II 4D (03->09)	T=250 mm	Z=350 mm
DAIHATSU Cuore VI 5D (03->06)	T=250 mm	Z=450 mm
DAIHATSU Trevis 5D (06->10)	T=350 mm	Z=350 mm
KIA Picanto I 5D (04->10)	T=250 mm	Z=500 mm
MERCEDES C Class 4D W203 (00->07)	T=200 mm	Z=300 mm
MERCEDES E Class 4D W211 (02->08)	T=230 mm	Z=370 mm
OPEL Agila A MPV (00->07) No rails	T=250 mm	Z=450 mm
SUZUKI Wagon R + 5D (97->00) No rails	T=250 mm	Z=450 mm
SUZUKI Wagon R + 5D (00->07) No rails	T=250 mm	Z=450 mm

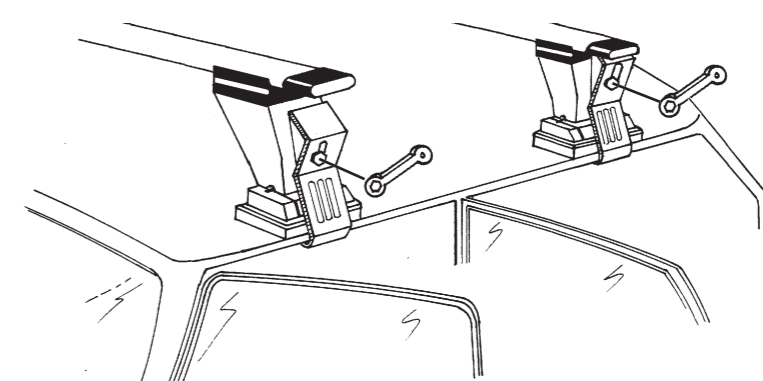

5 Nm

(D) FESTSCHRAUBEN
(GB) TO SCREW
(F) VISSER
(E) APRETAR
(IT) AVVITARE
(NL) VASTSCHROEVEN

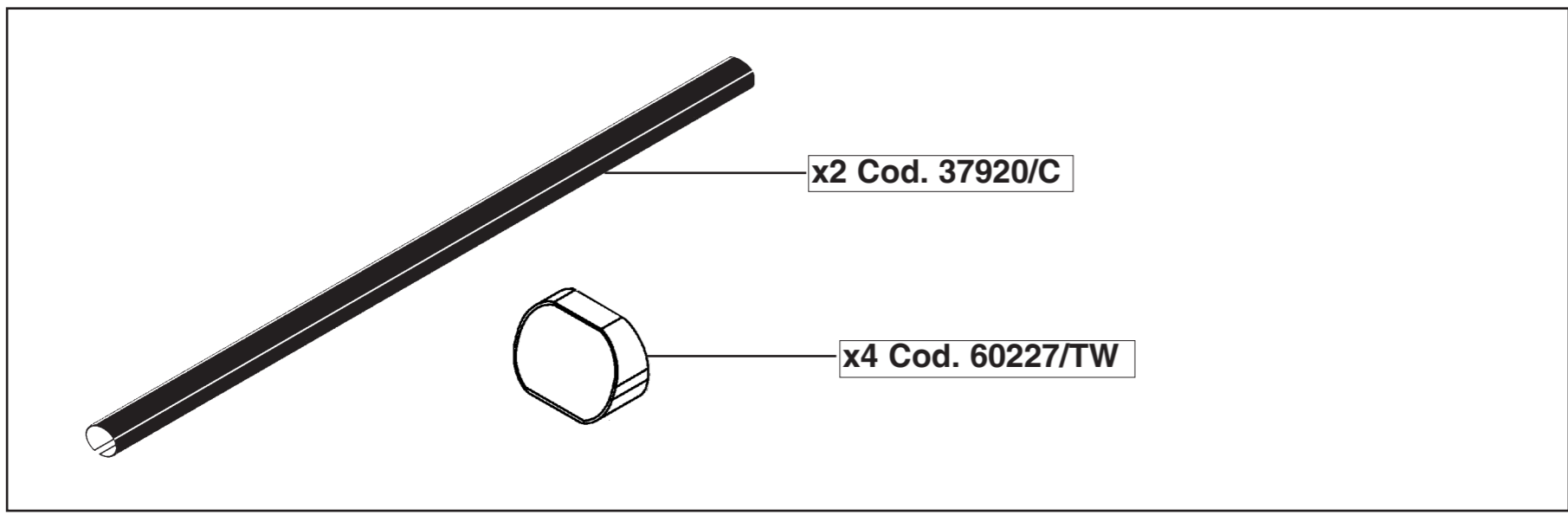
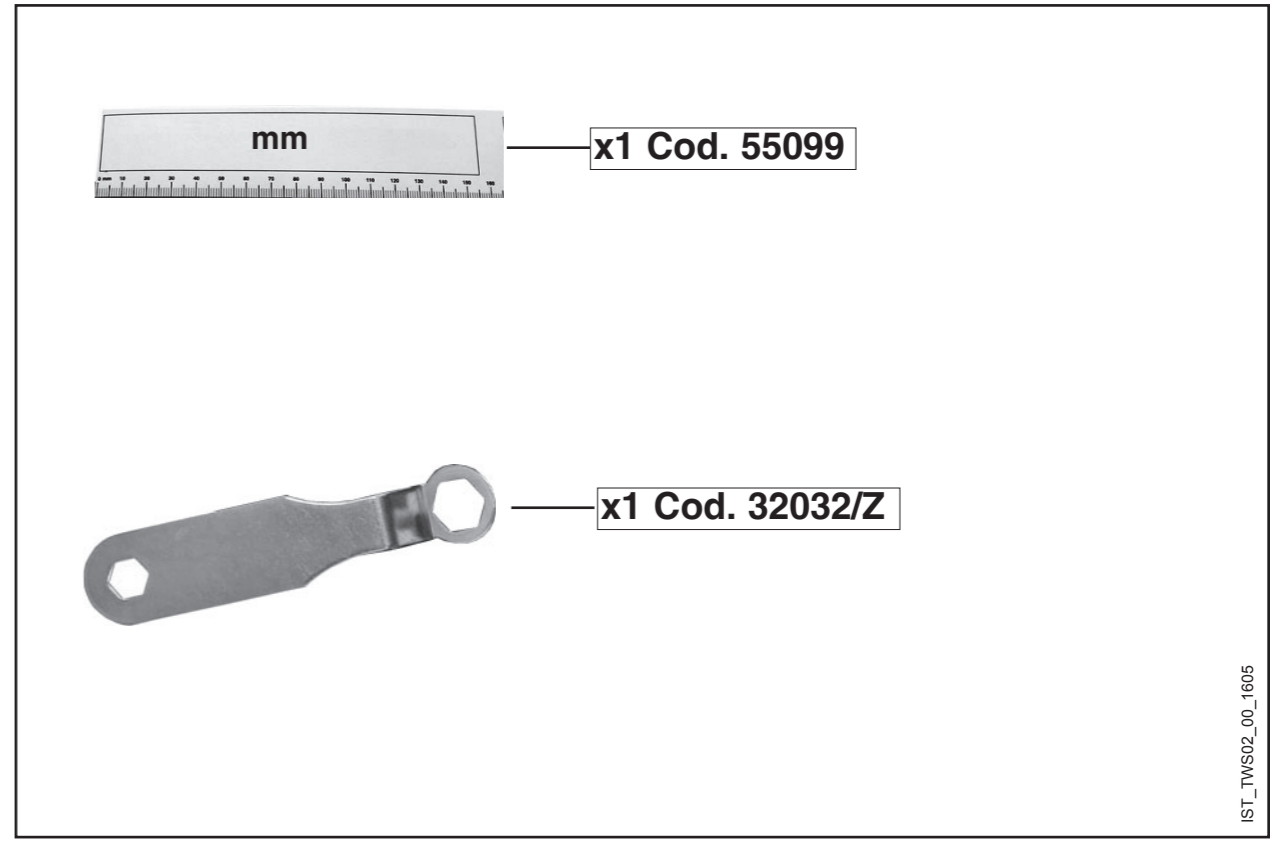
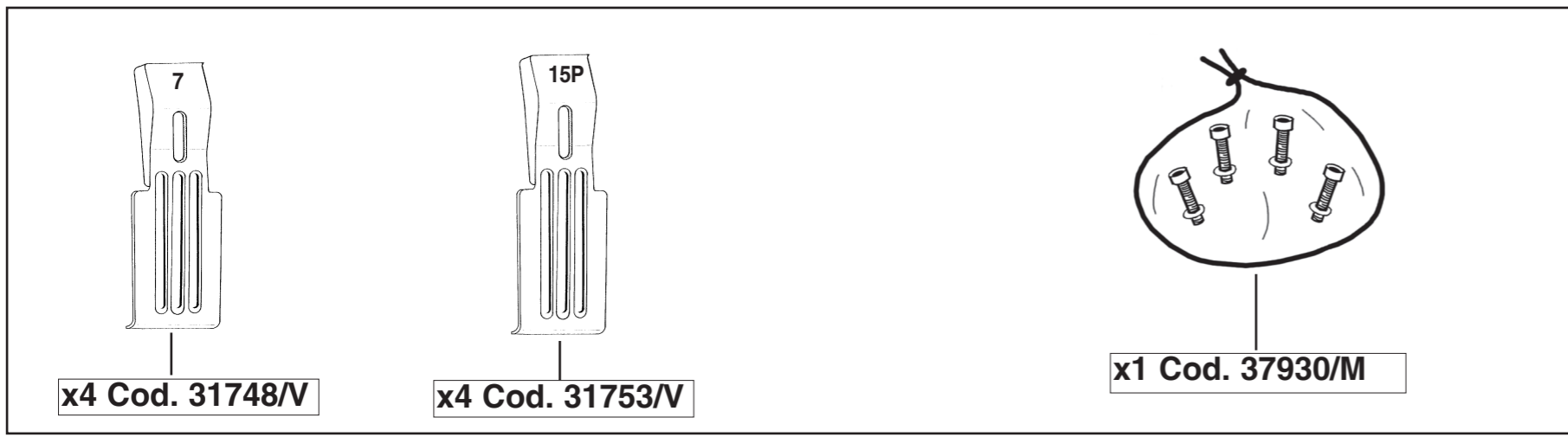
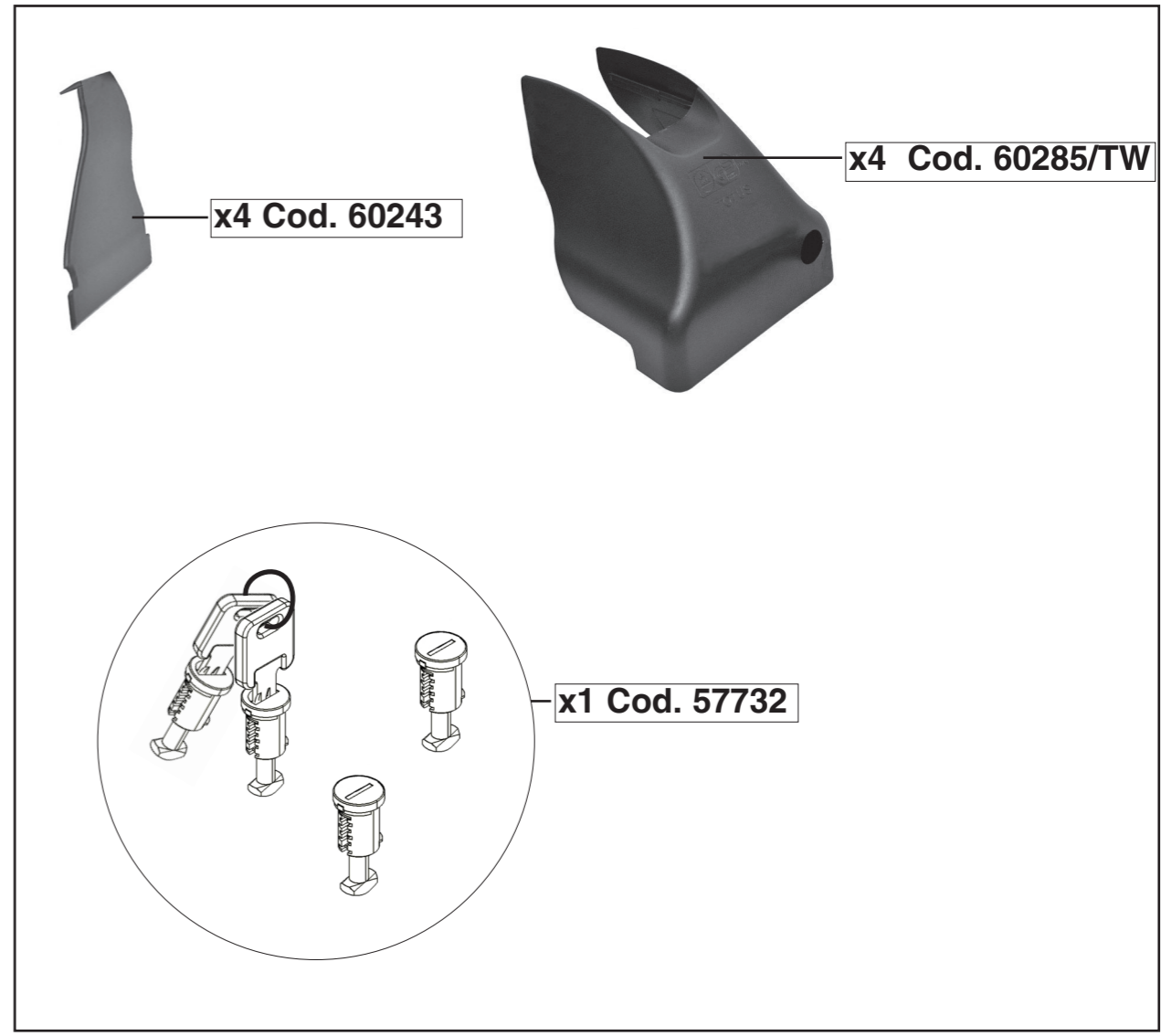
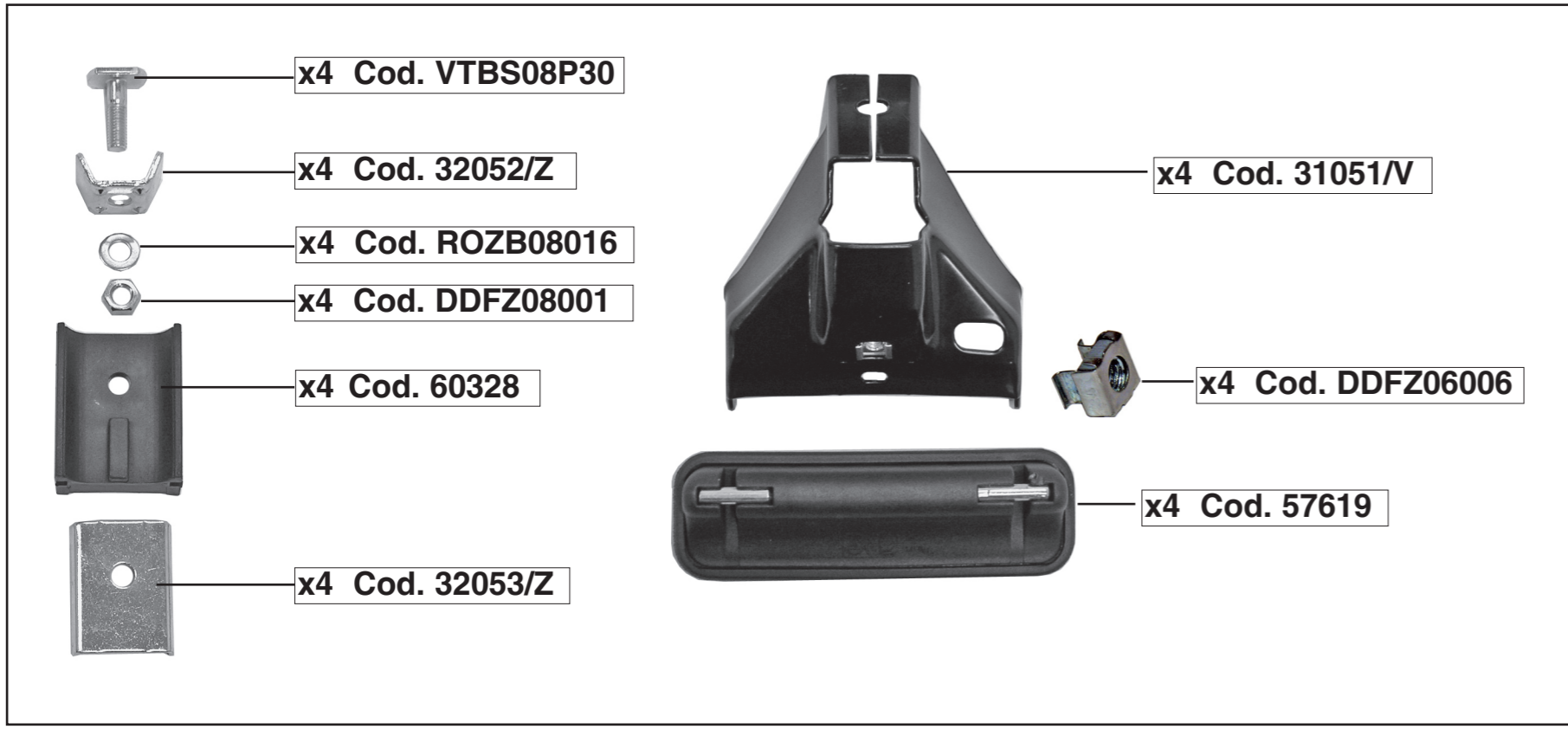

COVERS

1

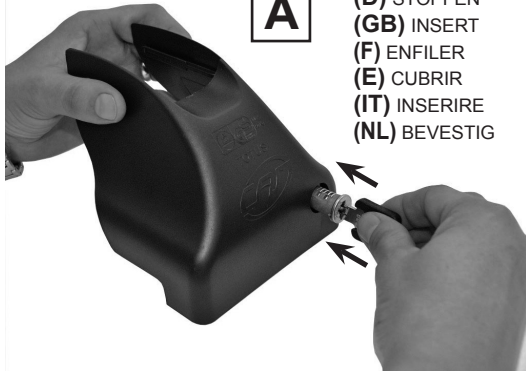

A

(D) STOPFEN
(GB) INSERT
(F) ENFILER
(E) CUBRIR
(IT) INSERIRE
(NL) BEVESTIG

ZOOM

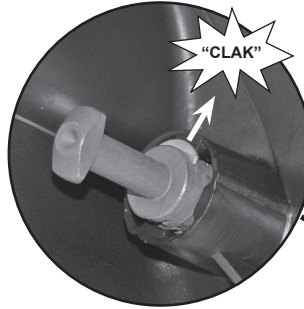

B

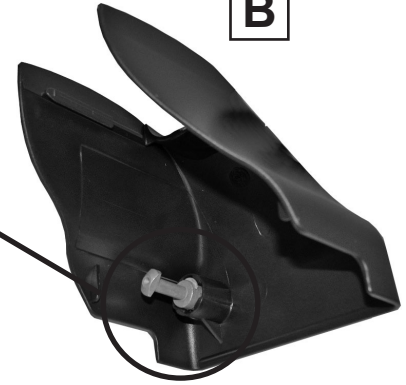

C



(D) STOPFEN
(GB) INSERT
(F) ENFILER
(E) CUBRIR
(IT) INSERIRE
(NL) BEVESTIG

2

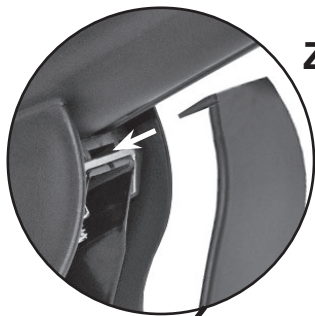

ZOOM

(D) STOPFEN
(GB) INSERT
(F) ENFILER
(E) CUBRIR
(IT) INSERIRE
(NL) BEVESTIG

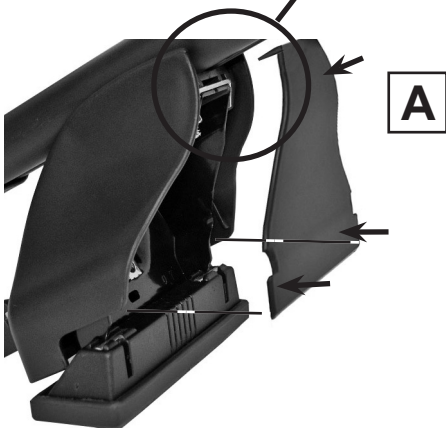

A

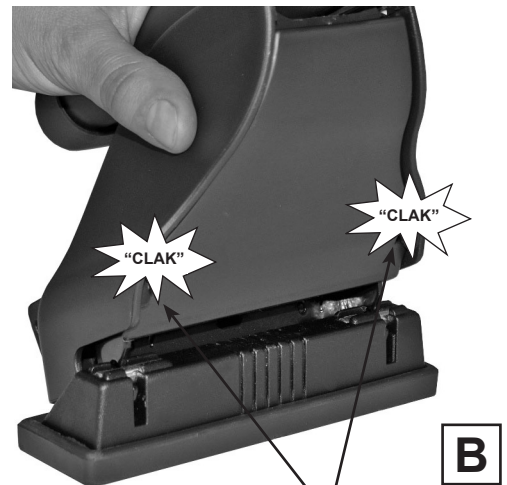

B

(D) STOPFEN
(GB) INSERT
(F) ENFILER
(E) CUBRIR
(IT) INSERIRE
(NL) BEVESTIG

I NORME D'ESTATE A PORTATUTTO UNIVERSALI CONFORMI ALLE NORME DIN 75302 E CONTRASSEGNA TI CON IL MARCHIO "GS".

- Effettuato il montaggio del portatutto, dopo alcuni chilometri ricontrrollare il fissaggio di tutte le viti.
 - È necessario periodicamente, anche in funzione del fondo stradale, controllare i fissaggi di tutte le viti.
 - Attenzione: la stabilità della vettura con portatutto montato può subire alterazioni nel comportamento su strada, nelle curve, nelle frenate ed in presenza di raffiche di vento. Si raccomanda quindi di guidare ed affrontare le curve a velocità moderata e di evitare brusche accelerate o frenate.
 - Per motivi di sicurezza e di risparmio carburante è preferibile smontare il portatutto in caso di inutilizzo.
 - **ATTENZIONE:** portata massima 50 kg distribuiti uniformemente sulle due barre.
- Attenzione: controllare sul libretto istruzioni della casa costruttrice la portata massima consentita dalla vostra vettura.

GB USING THE MULTI-PURPOSE RACK A3 PROVIDED FOR BY THE DIN 75302 STANDARD AND COUNTERSIGNED BY THE "GS" MARK.

- After rack assembly and few miles drive, ensure the bolts have been well tightened.
 - Periodically check the tightening of all bolts, with particular reference to the effect of varying road surfaces.
 - Caution: if the rack carries any load, vehicle stability may be affected, especially as regards roadholding in bends or in gusts and braking. Therefore, do not take bends at high speed and refrain from braking or accelerating sharply.
 - When not in use, the rack should be taken off the car to improve safety and cut down on fuel consumption.
 - It is not advisable to use a drive-through car wash with the rack still on top of the vehicle.
 - **IMPORTANT:** maximum load 50 kg to be distributed evenly between both bars.
- Please keep within the load limits as provided for by your car manufacturer (refer to the user's manual of your vehicle).

F MODE D'EMPLOI DES PORTE-BAGAGES UNIVERSELS CONFORMES AUX NORMES DIN 75302 ET CONTRESIGNE DE LA MARQUE "GS".

- Monter le porte-bagages: après quelques kilomètres, contrôler le serrage de toutes les vis.
- Vérifier périodiquement le serrage de toutes les vis en tenant compte de l'état des routes.
- Attention: la voiture équipée de porte-bagages peut subir des modifications dans la tenue de route, dans les virages, durant le freinage et en la présence de rafales de vent. Nous conseillons, par conséquent de conduire et d'aborder les virages à vitesse modérée et d'éviter de freiner et d'accélérer brusquement.
- Pour des raisons de sécurité et d'économie de carburant, il est préférable de démonter le porte-bagages en cas de non utilisation.
- **IMPORTANT:** capacité maximale de charge autorisée 50 kg, répartis uniformément sur les deux barres.
- Se conformer aux instructions du constructeur de la voiture en ce qui concerne la charge maximale autorisée du véhicule.

E INSTRUCCIONES DE USO DE LOS PORTATODOS UNIVERSALES CONFORME A LAS NORMAS DIN 75301 Y CONTRASEÑADOS CON LA MARCA "GS".

- Efectuado el montaje del portatodo, después de unos kilómetros, verificar que todos los tornillos sigan bien fijados.
 - Será necesario verificar, periódicamente y en función de tipo de carretera, las fijaciones de todos los tornillos.
 - Atención: la estabilidad del automóvil con el montaje del portatodo puede sufrir algunos cambios: en curvas, mientras el frenado y si hay ráfagas de viento. Pos eso, se recomienda conducir y girar a velocidad moderada y evitar los virajes bruscos, frenazos y acelerones.
 - Por razones de seguridad y ahorro de combustible, se sugiere desmontar el portatodo cuando no sea necesario su uso.
 - **IMPORTANTE:** peso máximo 50 kg repartidos entre las dos barras.
- Atención: verifiquen en el manual de instrucciones de su automóvil la capacidad máxima permitida.

D GEBRAUCHSANWEISUNG FÜR UNIVERSAL-DACHSKITRÄGER IM EINKLANG MIT DIN 75302 UND MIT GS-KENNZEICHEN.

- Fahren Sie nach Befestigung des Skiträgers einige Kilometer und überprüfen Sie dann nochmals alle Schrauben auf sichere Befestigung.
- Abhängig von der Ebenheit der Straßendecke sind sämtliche Schrauben regelmäßig nach zu kontrollieren.
- Achtung: Bei montiertem Dach-Skiträger kann sich das Fahrverhalten des Fahrzeugs ändern, insbesondere in Kurven, beim Bremsen und bei Windböen. Es empfiehlt sich daher, allgemein sowie speziell in Kurven mit mäßiger Geschwindigkeit zu fahren und abruptes Beschleunigen bzw. Bremsen zu vermeiden.
- Aus Sicherheitsgründen und zur Minderung des Kraftstoffverbrauchs sollten Sie den Dach-Skiträger möglichst abmontieren wenn er nicht benötigt wird.
- **ACHTUNG:** (max 50 kg) In der Gebrauchsanweisung des Fabrikanten die Höchstbelastbarkeit Ihres Wagens nachschlagen.

NL GEBRUIKSNORMEN VAN DE BAGAGEDRAGERS IN OVEREENSTEMMING MET DIN 75302 NORMEN EN GECONTRASIGNEERD MET MERKTEKEN "GS".

- Controleer, eens de bagagedrager volledig is gemonteerd, na enkele kilometers of alle schroeven goed vastzitten.
 - Kijk achteraf en volgens de aard van de wegen die bereden worden regelmatig na of alle schroeven wel degelijk vastzitten.
 - Let op: na het monteren van de bagagedrager kan de stabiliteit van de wagen verschillen, vooral in bochten, bij het remmen en bij krachtige windstoten. Wij raden dan ook aan voorzichtig te rijden, bochten met verminderde snelheid te nemen, niet te bruusk te nemen en niet te snel op te trekken.
 - Om veiligheidsredenen en om brandstof te besparen is het aangeraden de bagagedrager na gebruik weer van uw auto te halen.
 - **BELANGRUK:** maximum belasting 50 kg gelijkmatig verdeeld over de hele bagagedrager de maximum belasting van uw wagen.
- Aangegeven door de autoconstructeur in de handleiding van de wagen, niet overschrijden.

